

# User Manual

## ECU-12XX Series

(1251/1251V2/1251D/1252/1260)

**ADVANTECH**

*Enabling an Intelligent Planet*

---

## Copyright

The documentation and the software included with this product are copyrighted 2024 by Advantech Co., Ltd. All rights are reserved. Advantech Co., Ltd. reserves the right to make improvements in the products described in this manual at any time without notice. No part of this manual may be reproduced, copied, translated, or transmitted in any form or by any means without the prior written permission of Advantech Co., Ltd. The information provided in this manual is intended to be accurate and reliable. However, Advantech Co., Ltd. assumes no responsibility for its use, nor for any infringements of the rights of third parties that may result from its use.

## Acknowledgments

Intel, Pentium, Celeron and Atom are trademarks of Intel Corporation.  
Microsoft Windows and MS-DOS are registered trademarks of Microsoft Corp.  
All other product names or trademarks are properties of their respective owners.

## Support

For more information on this and other Advantech products, please visit our websites at: <http://www.advantech.com>  
For technical support and service, please visit our support website at: <http://www.advantech.com/support/>

## Product Warranty (2 years)

Advantech warrants the original purchaser that each of its products will be free from defects in materials and workmanship for two years from the date of purchase.

This warranty does not apply to any products that have been repaired or altered by persons other than repair personnel authorized by Advantech, or products that have been subject to misuse, abuse, accident, or improper installation. Advantech assumes no liability under the terms of this warranty as a consequence of such events.

Because of Advantech's high quality-control standards and rigorous testing, most customers never need to use our repair service. If an Advantech product is defective, it will be repaired or replaced free of charge during the warranty period. For out-of-warranty repairs, customers will be billed according to the cost of replacement materials, service time, and freight. Please consult your dealer for more details.

If you believe your product to be defective, follow the steps outlined below.

1. Collect all the information about the problem encountered. (For example, CPU speed, Advantech products used, other hardware and software used, etc.) Note anything abnormal and list any onscreen messages displayed when the problem occurs.
2. Call your dealer and describe the problem. Please have your manual, product, and any helpful information readily available.
3. If your product is diagnosed as defective, obtain a return merchandise authorization (RMA) number from your dealer. This allows us to process your return more quickly.
4. Carefully pack the defective product, a completed Repair and Replacement Order Card, and a proof of purchase date (such as a photocopy of your sales receipt) into a shippable container. Products returned without a proof of purchase date are not eligible for warranty service.
5. Write the RMA number clearly on the outside of the package and ship the package prepaid to your dealer.

## Declaration of Conformity

### CE

This product has passed the CE test for environmental specifications when shielded cables are used for external wiring. We recommend the use of shielded cables. This type of cable is available from Advantech. Please contact your local supplier for ordering information.

Test conditions for passing also include the equipment being operated within an industrial enclosure. In order to protect the product from damage caused by electrostatic discharge (ESD) and EMI leakage, we strongly recommend the use of CE-compliant industrial enclosure products.

### FCC Class A

This equipment has been tested and found to comply with the limits for a Class A digital device, pursuant to part 15 of the FCC Rules. These limits are designed to provide reasonable protection against harmful interference when the equipment is operated in a commercial environment. This equipment generates, uses, and can radiate radio frequency energy and, if not installed and used in accordance with the instruction manual, may cause harmful interference to radio communications. Operation of this equipment in a residential area is likely to cause harmful interference. In this event, users are required to correct the interference at their own expense.

## Technical Support and Assistance

1. Visit the Advantech website at [www.advantech.com/support](http://www.advantech.com/support) to obtain the latest product information.
2. Contact your distributor, sales representative, or Advantech's customer service center for technical support if you need additional assistance. Please have the following information ready before calling:
  - Product name and serial number
  - Description of your peripheral attachments
  - Description of your software (operating system, version, application software, etc.)
  - A complete description of the problem
  - The exact wording of any error messages

## Packing List

Before system installation, check that the items listed below are included and in good condition. If any item does not accord with the list, contact your dealer immediately.

- ECU-12XX
- 1 x warranty card
- Connector
- Din rail
- Screws

## Safety Instructions

1. Read these safety instructions carefully.
2. Retain this user manual for future reference.
3. Disconnect the equipment from all power outlets before cleaning. Use only a damp cloth for cleaning. Do not use liquid or spray detergents.
4. For pluggable equipment, the power outlet socket must be located near the equipment and easily accessible.
5. Protect the equipment from humidity.
6. Place the equipment on a reliable surface during installation. Dropping or letting the equipment fall may cause damage.
7. The openings on the enclosure are for air convection. Protect the equipment from overheating. Do not cover the openings.
8. Ensure that the voltage of the power source is correct before connecting the equipment to a power outlet.
9. Position the power cord away from high-traffic areas. Do not place anything over the power cord.
10. All cautions and warnings on the equipment should be noted.
11. If the equipment is not used for a long time, disconnect it from the power source to avoid damage from transient overvoltage.
12. Never pour liquid into an opening. This may cause fire or electrical shock.
13. Never open the equipment. For safety reasons, the equipment should be opened only by qualified service personnel.
14. If any of the following occurs, have the equipment checked by service personnel:
  - The power cord or plug is damaged.
  - Liquid has penetrated the equipment.
  - The equipment has been exposed to moisture.
  - The equipment is malfunctioning, or does not operate according to the user manual.
  - The equipment has been dropped and damaged.
  - The equipment shows obvious signs of breakage.
15. Do not leave the equipment in an environment with a storage temperature of below  $-25^{\circ}\text{C}$  ( $-13^{\circ}\text{F}$ ) or above  $70^{\circ}\text{C}$  ( $158^{\circ}\text{F}$ ) as this may damage the components. The equipment should be kept in a controlled environment.
16. **CAUTION:** Batteries are at risk of exploding if incorrectly replaced. Replace only with the same or equivalent type as recommended by the manufacturer. Discard used batteries according to the manufacturer's instructions.
17. Due to the sensitive nature of the equipment it must be stored in a restricted access location, only accessible by qualified engineers.
18. When installing this equipment, ensure that the Earth cable is securely attached using a 3.5mm screw.
19. The equipment does not include a power cord and plug.
20. In accordance with IEC 704-1:1982 specifications, the sound pressure level at the operator's position does not exceed 70 dB (A).

DISCLAIMER: These instructions are provided according to IEC 704-1 standards. Advantech disclaims all responsibility for the accuracy of any statements contained herein.

---

## Safety Precautions - Static Electricity

Follow these simple precautions to protect yourself from harm and the products from damage.

- To avoid electrical shock, always disconnect the power from the PC chassis before manual handling. Do not touch any components on the CPU card or other cards while the PC is powered on.
- Disconnect the power before making any configuration changes. A sudden rush of power after connecting a jumper or installing a card may damage sensitive electronic components.

# Contents

<b>Chapter 1</b>	<b>Overview.....</b>	<b>1</b>
1.1	Introduction .....	2
1.2	Specifications .....	3
1.2.1	General .....	3
1.2.2	System .....	3
1.2.3	Communication .....	3
1.2.4	Software .....	3
1.2.5	Environment .....	4
1.3	Safety Precautions .....	4
1.4	Chassis Dimensions .....	5
	Figure 1.1 ECU-1251/1251V2 Chassis Dimensions .....	5
	Figure 1.2 ECU-1251D Chassis Dimensions .....	5
	Figure 1.3 ECU-1252 Chassis Dimensions .....	6
	Figure 1.4 ECU-1260 Chassis Dimensions .....	6
<b>Chapter 2</b>	<b>Hardware Functionality .....</b>	<b>7</b>
2.1	Overview .....	8
	Figure 2.1 ECU-1251/1251V2 Overview .....	8
	Figure 2.2 ECU-1251D Overview .....	8
	Figure 2.3 ECU-1252 Overview .....	8
	Figure 2.4 ECU-1260 Overview .....	8
2.2	LED Status Indicators .....	9
	Figure 2.5 ECU-1251/1251V2/ECU-1251D/ECU-1252/ECU-1260 LED Status Indicator .....	9
2.2.1	System Status Indicators .....	9
	Table 2.1: System Status Indicators .....	9
2.2.2	Serial and CAN Communication Status Indicator .....	10
	Figure 2.6 ECU-1251/1251V2/ECU-1251D/ECU-1252/ECU-1260 Serial Status Indicator .....	10
	Table 2.2: Serial Communication Status Indicator .....	10
2.2.3	Ethernet Status Indicator .....	11
	Table 2.3: ECU-1251, ECU-1251D .....	11
	Table 2.4: ECU-1252/1251V2 .....	11
<b>Chapter 3</b>	<b>Wiring and Installation .....</b>	<b>13</b>
3.1	Wiring .....	14
3.1.1	Power Supply Wiring .....	14
	Figure 3.1 Power Supply Wiring .....	14
	Table 3.1: AC/DC Power Input Connector Pin Definition .....	14
3.1.2	Communication Ports .....	14
	Figure 3.2 ECU-1251/1251V2/ECU-1251D/ECU-1252/ECU-1260 Serial and CAN Ports .....	14
	Table 3.2: RS-232/485 Serial Ports (Pin Assignments) .....	14
3.1.3	USB Port .....	15
	Figure 3.3 USB Connector .....	15
	Table 3.3: USB Connector Pin Assignment .....	15
3.1.4	LAN Port .....	15
	Figure 3.4 LAN Connectors .....	15
	Table 3.4: LAN Connector Pin Assignments .....	15
3.1.5	Node ID .....	16
	Figure 3.5 Dial Switch Setting .....	16

	Table 3.5: ECU-1251 Node ID Setting .....	16
3.1.6	Digital Input/Digital Output Port .....	16
	Figure 3.6 DI/O Wiring.....	16
3.2	Jumper Setting.....	17
3.2.1	Jumper Setting.....	17
	Figure 3.7 ECU-1251 Jumper on the Back Motherboard .....	17
	Figure 3.8 ECU-1251D Jumper on the Back Motherboard.....	17
	Figure 3.9 ECU-1252/1251V2 Jumper on the Back Motherboard .	18
	Figure 3.10 ECU-1260 Jumper on the Back Motherboard .....	18
	Table 3.6: Jumper Setting of Terminal Resistor For COM .....	19
3.2.2	Debug Port.....	19
	Table 3.7: Pin Definition .....	19
	Table 3.8: Configuration .....	19
3.3	Installation.....	20
3.3.1	Wall-mounted and DIN-Rail Installation.....	20
	Figure 3.11 Wall-mounted Installation .....	20
	Figure 3.12 Vertical DIN-Rail Bracket Installation .....	21
	Figure 3.13 Vertical DIN-Rail Installation.....	21
3.3.2	SD&SIM Card Installation.....	21
	Figure 3.14 SD &SIM Card Installation.....	21
3.3.3	Installing a Wireless Module Card and Antenna (Optional).....	22



# Chapter 1

## Overview

## 1.1 Introduction

For solar power, electricity and factory related applications which require a total wireless and Ethernet communication solutions, Advantech has released the ECU-12XX RISC-based industrial communication gateway. ECU-1251 has an open platform design with Cortex A8 processor, up to four RS-232/485 isolated serial ports, two 10/100 Ethernet ports and operating temperature range of -40~70° C. ECU-1251D has additional 4DI/4DO while ECU-1252 has CAN\*2 and ECU-1260 has CAN\*1. The Linux operating system and open TagLink SDK enable system integrators to develop applications which precisely fit their need.

ECU-1251/1251V2



ECU-1251D



ECU-1252



ECU-1260



## 1.2 Specifications

### 1.2.1 General

- **Certification:** CE, FCC
- **Mounting:** Wall-Mount/DIN-Rail
- **Power Consumption:** 2.4W @ 24V<sub>DC</sub>
- **Power Requirements:** 10 ~ 30 V<sub>DC</sub>

### 1.2.2 System

- **CPU:**
  - TI Cortex A8, 800MHz (ECU-1251)
  - TI Cortex A8, 600MHz (ECU-1251D)
  - TI Cortex A9, 600MHz (ECU-1252/1251V2)
  - Cortex-A35 Quad Core, 1GHz (ECU-1260)
- **Memory:**
  - DDR3L 256MB (ECU-1251)
  - DDR3L 256MB (ECU-1251D)
  - DDR3L 2GB (ECU-1252/1251V2/1260)
- **Indicators:** Power, LAN (LINK, ACT), Serial (Tx, Rx), Programmable
- **Storage for system:**
  - 4GB Micro-SD card (ECU-1251)
  - 512MB NAND Flash (ECU-1251D)
  - 16GB eMMC (ECU-1252/1251V2/1260)
- **SD Slot:** 1 x Micro-SD slot
- **Watchdog:** Yes
- **Node ID:** 8-bit (ECU-1251)
- **Real-time clock:** Yes

### 1.2.3 Communication

- **Serial Port:**
  - 4 x RS-232/485 (ECU-1251/1251V2)
  - 3 x RS-232/485 (ECU-1260)
  - 2 x RS-232/485 (ECU-1251D/1252)
- **Isolation:** 3000 V<sub>DC</sub>
- **Serial Port Speed:** 50 ~ 115200 bps
- **Ethernet Port:** 2 x RJ-45 ports
- **USB Port:** 1 x USB2.0 (ECU-1251)
- **CAN Port:**
  - 2 x CAN (ECU-1252)
  - 1 x CAN (ECU-1260)
- **Wireless (Optional):** Interface: 1x Mini-PCIe (Full-size)

### 1.2.4 Software

- **OS Support:** Yocto Kernel 4.9
- **Programming:** Linux C
- **Login:** user name: root; password: no password (just press “Enter”)
- **Default IP:** LAN1:10.0.0.1, LAN2:11.0.0.1

### 1.2.5 Environment

- **Humidity:** 5~95% (non-condensing)
- **Operating Temperature:** -40 ~ 70° C
- **Storage Temperature:** -40~85° C

## 1.3 Safety Precautions

The following messages inform how to make each connection. In most cases, you will simply need to connect a standard cable.

**Warning!** *Always disconnect the power cord from your chassis whenever you are working on it. Do not connect while the power is on. A sudden rush of power can damage sensitive electronic components. Only experienced electronics personnel should open the chassis.*



**Caution!** *Always ground yourself to remove any static electric charge before touching ECU-12XX Series. Modern electronic devices are very sensitive to static electric charges. Use a grounding wrist strap at all times. Place all electronic components on a static-dissipative surface or in a static-shielded bag.*



**Note!** *If DC voltage is supplied by an external circuit, please put a protection device in the power supply input port.*



## 1.4 Chassis Dimensions

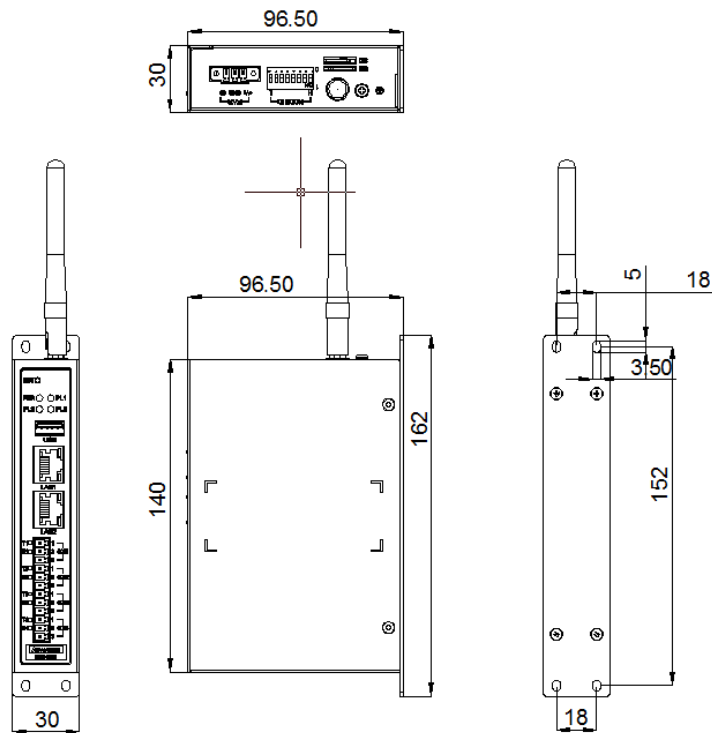

Figure 1.1 ECU-1251/1251V2 Chassis Dimensions

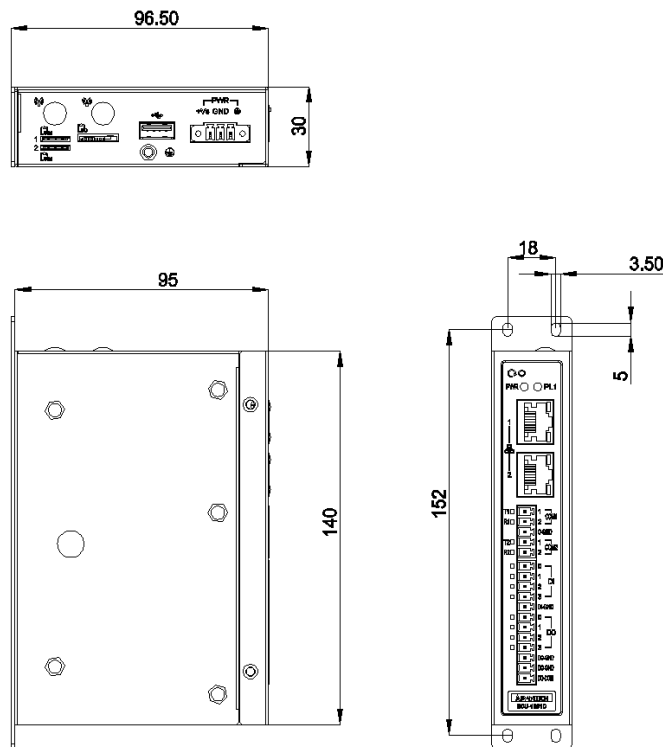

Figure 1.2 ECU-1251D Chassis Dimensions

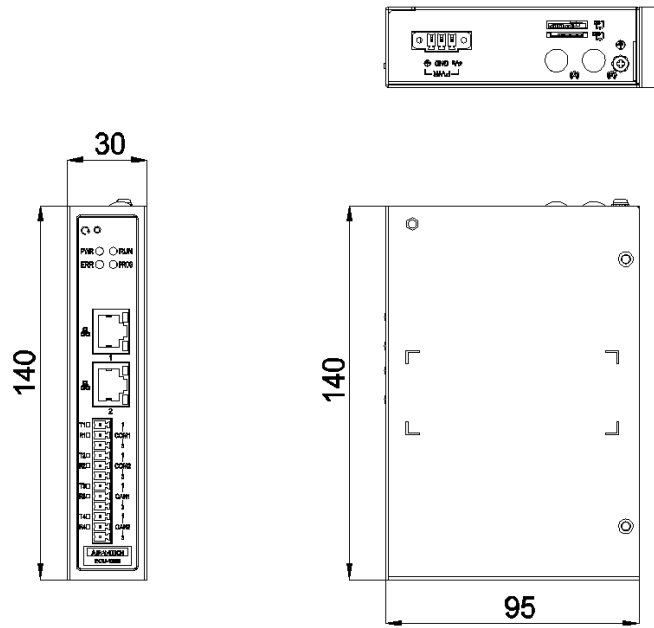

Figure 1.3 ECU-1252 Chassis Dimensions

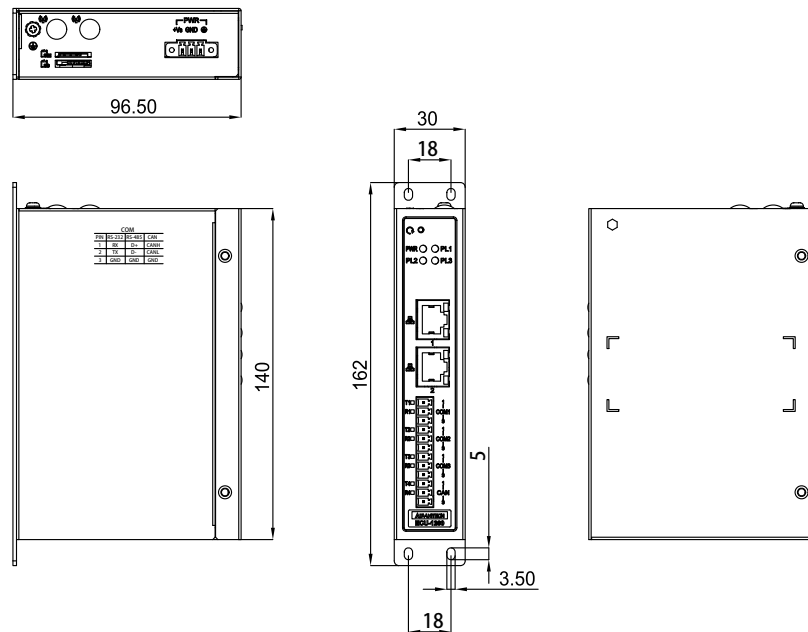

Figure 1.4 ECU-1260 Chassis Dimensions

# Chapter 2

Hardware  
Functionality

## 2.1 Overview

The following figures show the panel configuration. More information of each peripheral is included in the following sections.

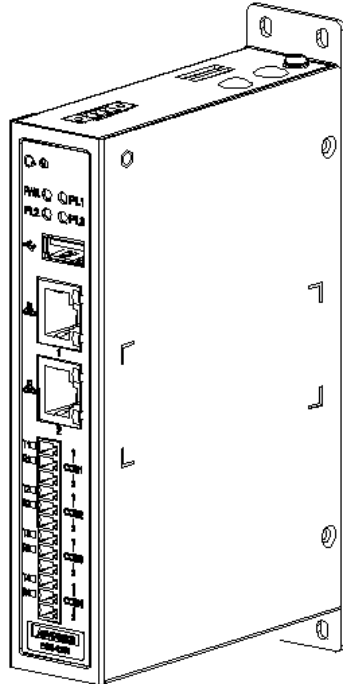

Figure 2.1 ECU-1251/1251V2 Overview

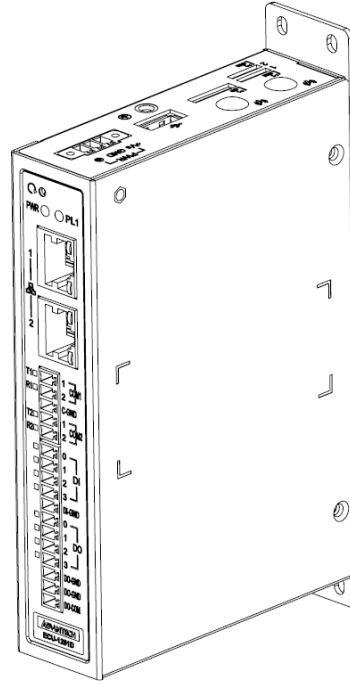

Figure 2.2 ECU-1251D Overview

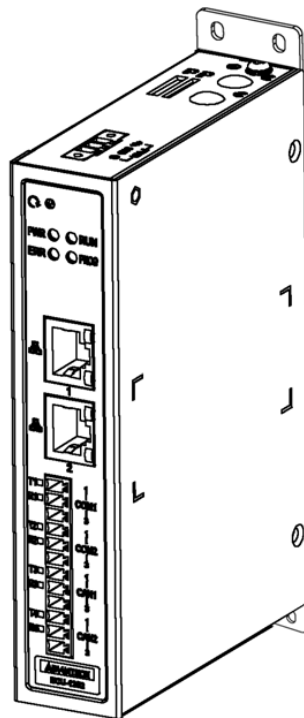

Figure 2.3 ECU-1252 Overview

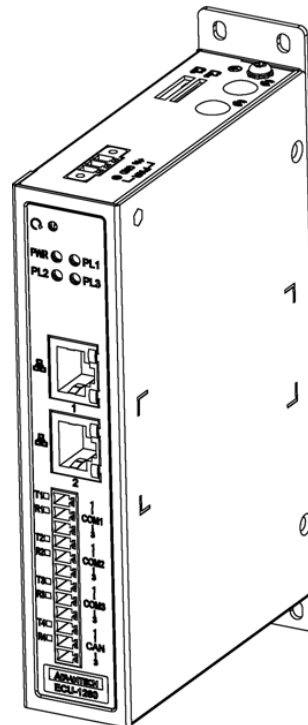

Figure 2.4 ECU-1260 Overview



## 2.2 LED Status Indicators

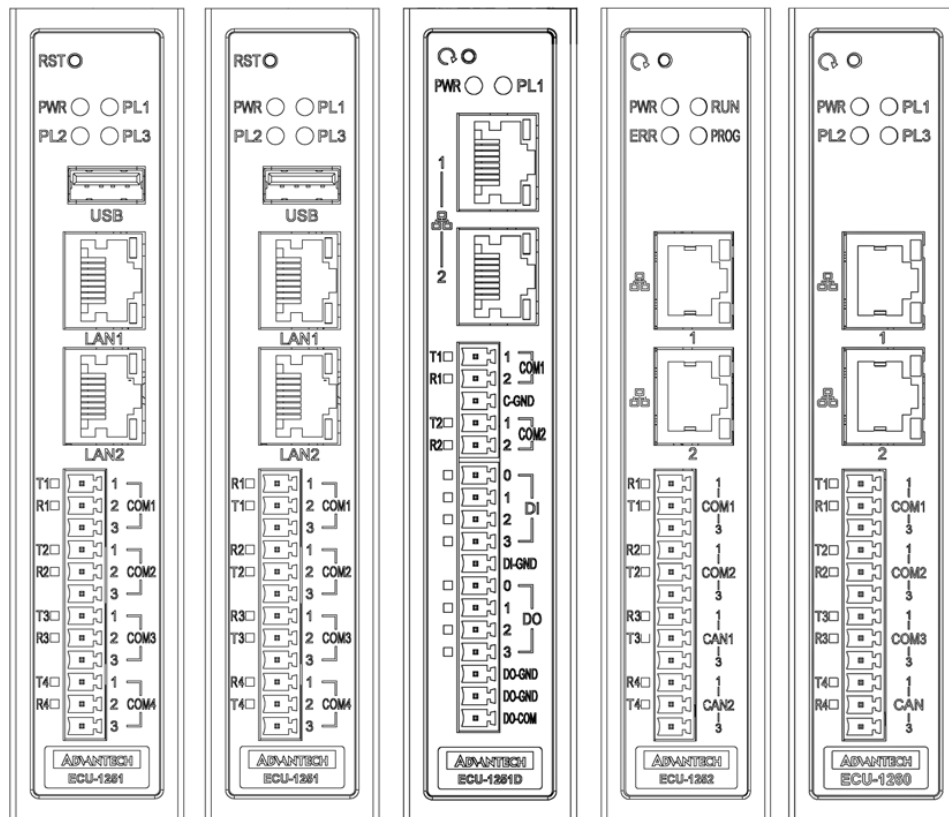

Figure 2.5 ECU-1251/1251V2/ECU-1251D/ECU-1252/ECU-1260 LED Status Indicator

### 2.2.1 System Status Indicators

<b>ECU-1251</b>	<b>ECU-1251D</b>	<b>ECU-1252/1251V2</b>	<b>ECU-1260</b>
PWR ○ ○ RUN	PWR ○ ○ PL1	PWR ○ ○ RUN	PWR ○ ○ PL1
ERR ○ ○ PROG		ERR ○ ○ PROG	PL2 ○ ○ PL3

Table 2.1: System Status Indicators

LED	Status	Description
PWR	Green	Power is on
	Off	Power is off
PL	Green	Heartbeat indicator of DataCollector (or DataCollector + KW)
	Off	No data is collected or operated
ERR	Green	Any item exception status
	Off	No exception
PROG	Green	Customers can define the programmable LED state according to their actual need
	Off	

## 2.2.2 Serial and CAN Communication Status Indicator

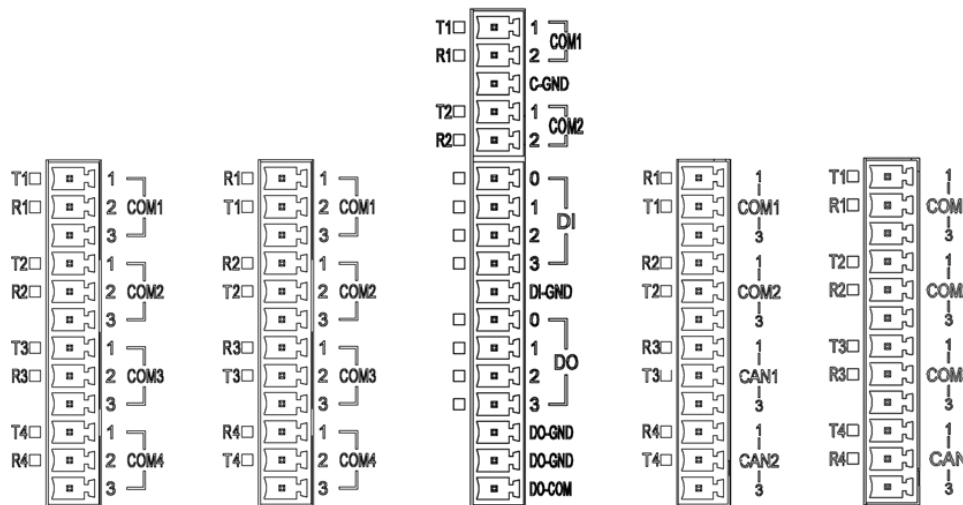
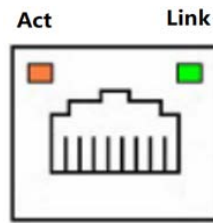

Figure 2.6 ECU-1251/1251V2/ECU-1251D/ECU-1252/ECU-1260 Serial Status Indicator

Table 2.2: Serial Communication Status Indicator		
LED	Color	Description
TX1	Orange	Blinking, Serial port 1 data being transmitted
RX1	Green	Blinking, Serial port 1 data being received
TX2	Orange	Blinking, Serial port 2 data being transmitted
RX2	Green	Blinking, Serial port 2 data being received
TX3	Orange	Blinking, Serial port 3 data being transmitted
RX3	Green	Blinking, Serial port 3 data being received
TX4	Orange	Blinking, Serial port 4 data being transmitted
RX4	Green	Blinking, Serial port 4 data being received

### 2.2.3 Ethernet Status Indicator

ECU-1251, ECU-1251D, ECU-1260



**Table 2.3: ECU-1251, ECU-1251D**

LED	Status	Description
Link (Port 1~2)	Off	10 Mbps network linked
	Green	100 Mbps network linked
Act (Port 1~2)	Orange On	No data being transmitted
	Orange Blinking	Data being transmitted

ECU-1252/1251V2

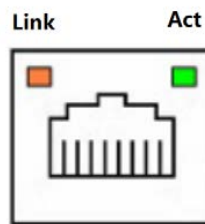

**Table 2.4: ECU-1252/1251V2**

LED	Status	Description
Link (Port 1~2)	Off	10 Mbps network linked
	Orange	100 Mbps network linked
	Green	1000 Mbps network linked
Act (Port 1~2)	Green On	No data being transmitted
	Green Blinking	Data being transmitted



# Chapter 3

## Wiring and Installation

### 3.1 Wiring

#### 3.1.1 Power Supply Wiring

ECU-12XX supports power input ranging from 10V<sub>DC</sub> to 30V<sub>DC</sub>.

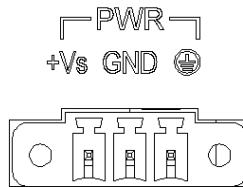

Figure 3.1 Power Supply Wiring

**Table 3.1: AC/DC Power Input Connector Pin Definition**

Function	Pin	Screen Printing	Function Description
Power Input	1	+Vs	PWR V+ DC power input PIN
	2	GND	PWR V- DC power input PIN
	3	⊕	GND

#### 3.1.2 Communication Ports

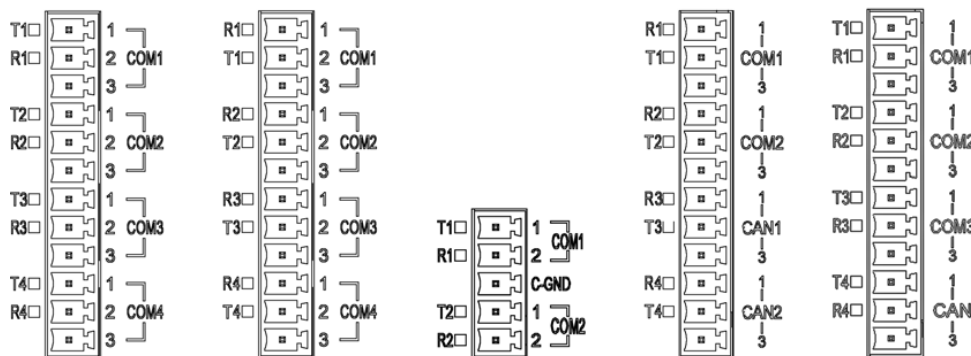

Figure 3.2 ECU-1251/1251V2/ECU-1251D/ECU-1252/ECU-1260 Serial and CAN Ports

**Table 3.2: RS-232/485 Serial Ports (Pin Assignments)**

Pins	1	2	3
RS-232	Rx	Tx	GND
RS-485	Data+	Data-	GND
CAN	CANH	CANL	GND

### 3.1.3 USB Port

ECU-1251 is equipped with one USB 2.0 Type A port for optional extension choice.

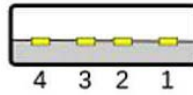

Figure 3.3 USB Connector

**Table 3.3: USB Connector Pin Assignment**

Pin	Signal
1	VCC
2	DATA-
3	DATA+
4	GND

### 3.1.4 LAN Port

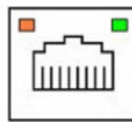

Figure 3.4 LAN Connectors

**Table 3.4: LAN Connector Pin Assignments**

Pin	Assignment	Description
1	TD+	Transmit+
2	TD-	Transmit-
3	RD+	Receive+
4	N/C	Not used
5	N/C	N/C
6	RD-	Receive-
7	N/C	N/C
8	N/C	N/C

### 3.1.5 Node ID

ECU-1251 has an 8-bit node ID.

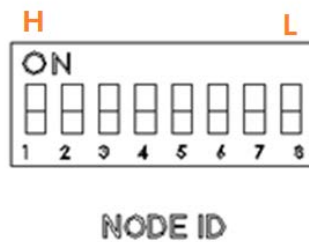

Figure 3.5 Dial Switch Setting

**Table 3.5: ECU-1251 Node ID Setting**

Node ID	8-bit, support 0~255 devices. In peer to peer application, the Node ID should be 1~255.
---------	---

### 3.1.6 Digital Input/Digital Output Port

ECU-1251D supports 4 digital input and 4 digital output ports, wiring is shown as below.

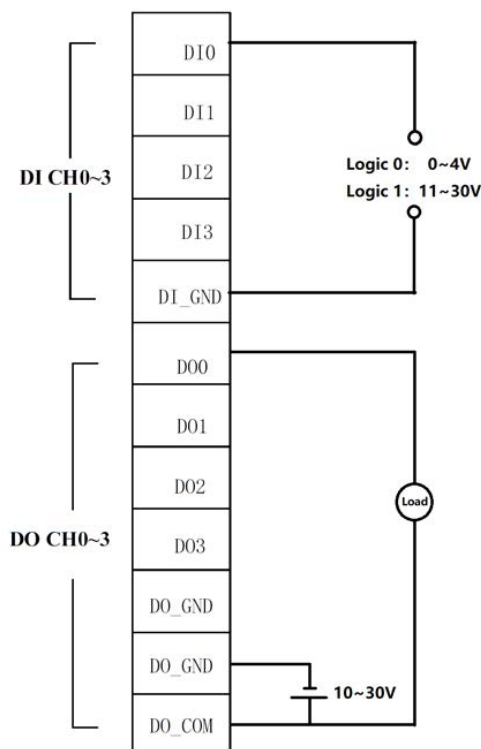

Figure 3.6 DI/O Wiring



## 3.2 Jumper Setting

### 3.2.1 Jumper Setting

The jumper in red square is for COM mode select and the the 3-pin jumper in green square is for debug port.

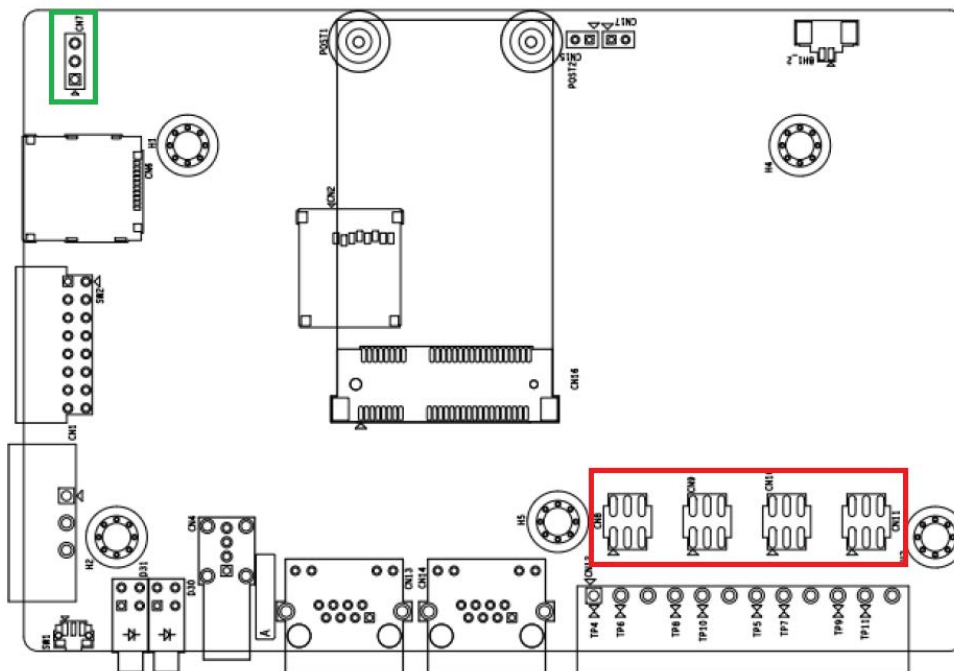

Figure 3.7 ECU-1251 Jumper on the Back Motherboard

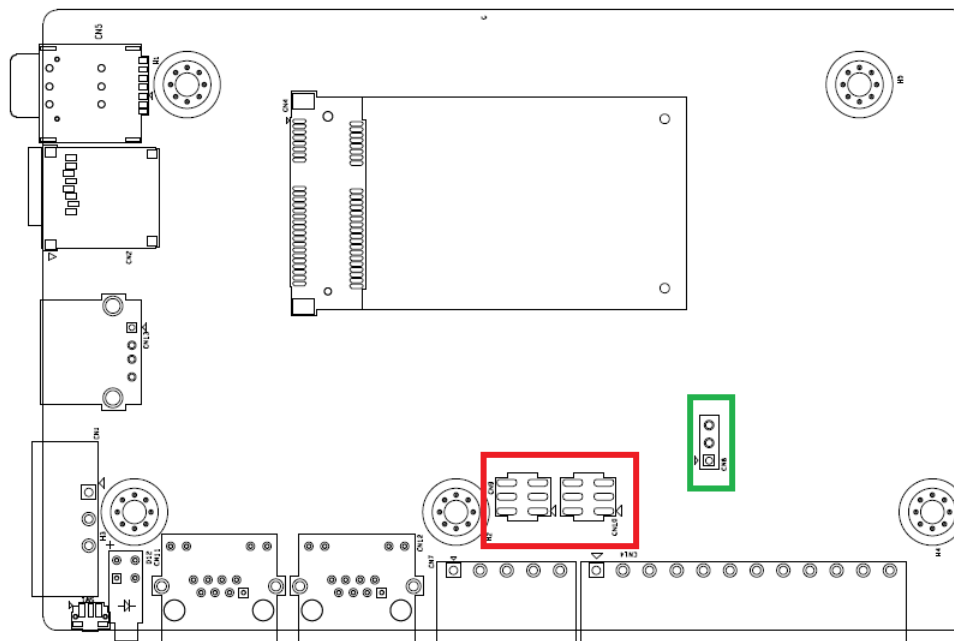
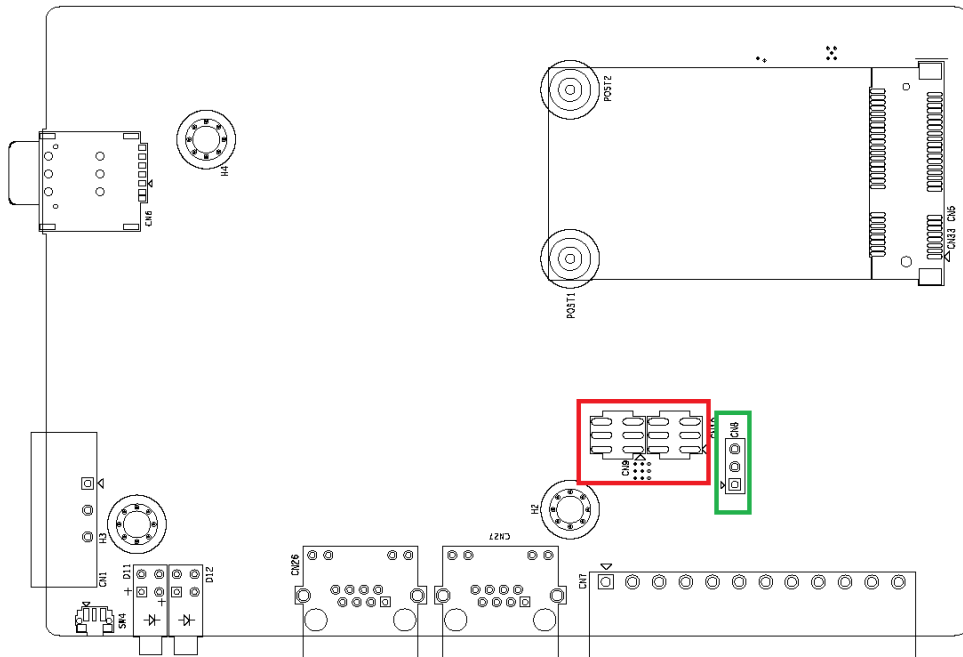
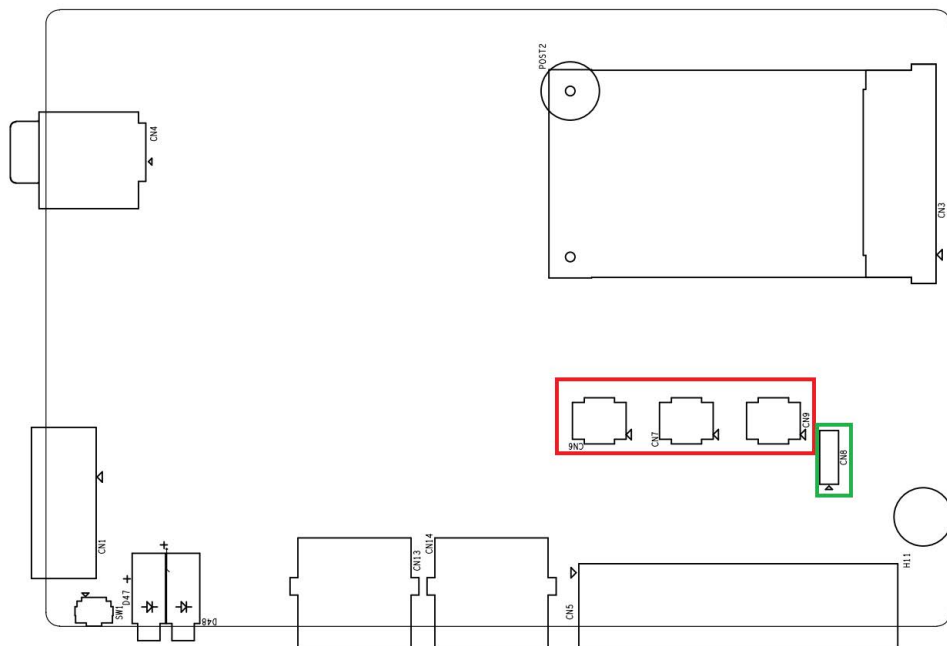

Figure 3.8 ECU-1251D Jumper on the Back Motherboard

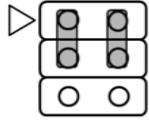
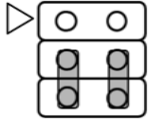

**Figure 3.9 ECU-1252/1251V2 Jumper on the Back Motherboard**

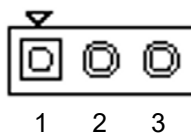

**Figure 3.10 ECU-1260 Jumper on the Back Motherboard**

**Table 3.6: Jumper Setting of Terminal Resistor For COM**

Location	Description
 CN8 CN9 CN10	Data+/Data- of RS-485
 CN10 CN11	RX/TX of RS-232

### 3.2.2 Debug Port



**Table 3.7: Pin Definition**

PIN	Definition
1	COM Debug TX
2	COM Debug RX
3	GND

**Table 3.8: Configuration**

Serial Port	RS-232
Baud Rate	115200
Parity	None
Data Bits	8
Stop Bits	1
Flow Control	None

### 3.3 Installation

#### 3.3.1 Wall-mounted and DIN-Rail Installation

ECU-12XX supports two types of installation: Wall-mounted and DIN-Rail Installation. For wall-mounted installation, users can fix the device on the wall with 4 screws as shown below.

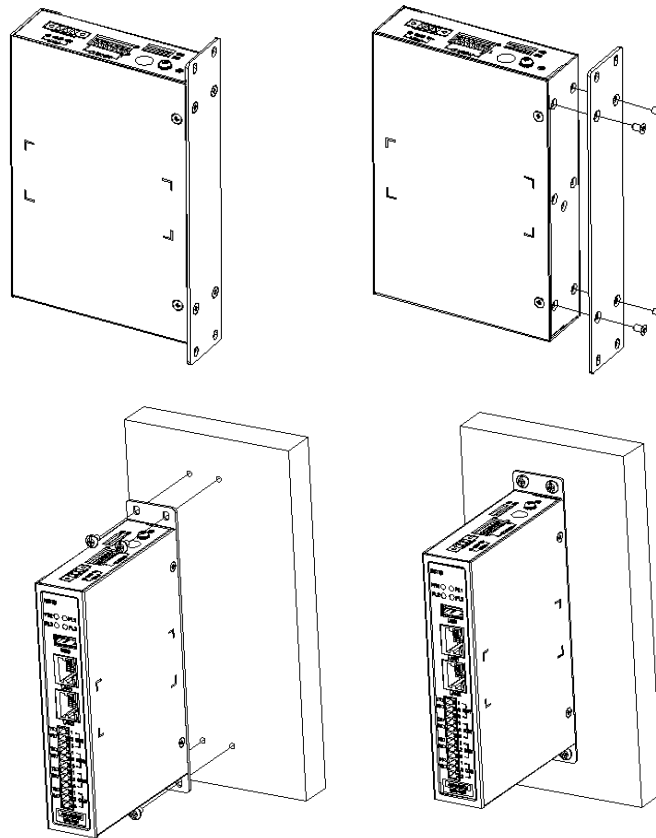
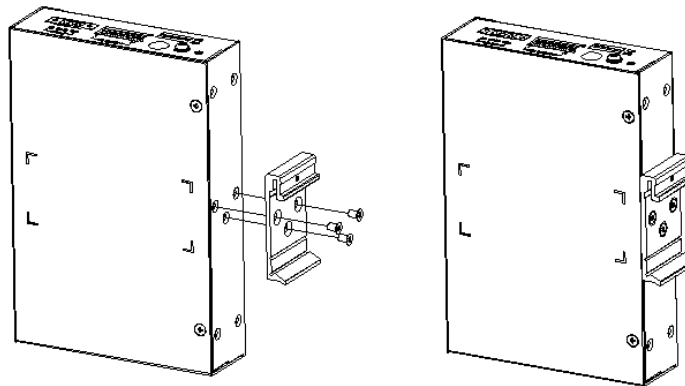
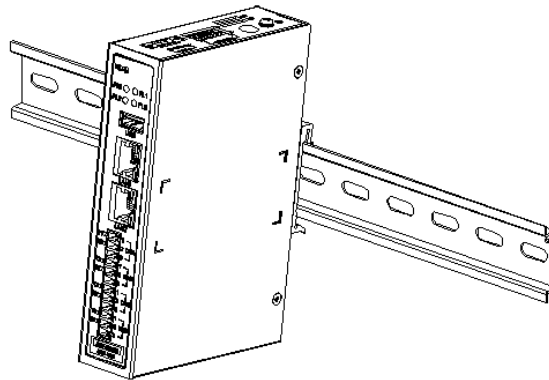

Figure 3.11 Wall-mounted Installation

For DIN-Rail installation. Assembly DIN-Rail bracket and install with screws on the back, then fix on the DIN-Rail itself - detailed steps are shown below:



**Figure 3.12 Vertical DIN-Rail Bracket Installation**



**Figure 3.13 Vertical DIN-Rail Installation**

### 3.3.2 SD&SIM Card Installation

ECU-12XX series is equipped with one Micro SD card slot and one SIM card slot. Please insert SIM card with pins downward and SD card with pins upward.

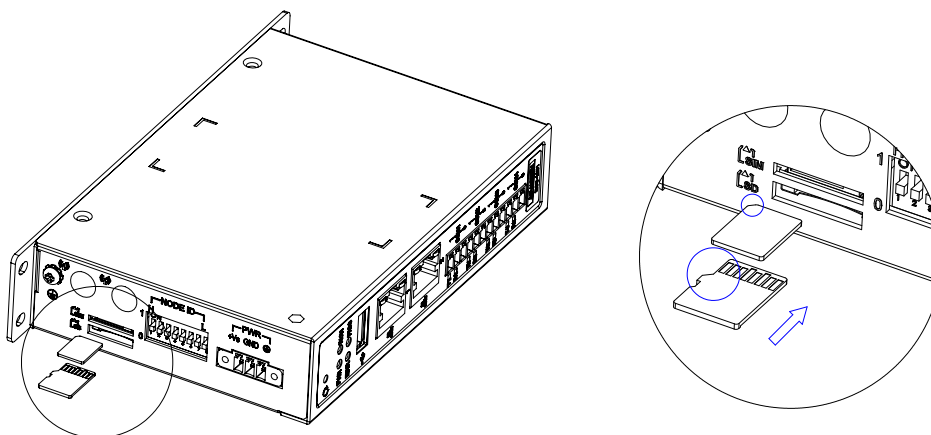
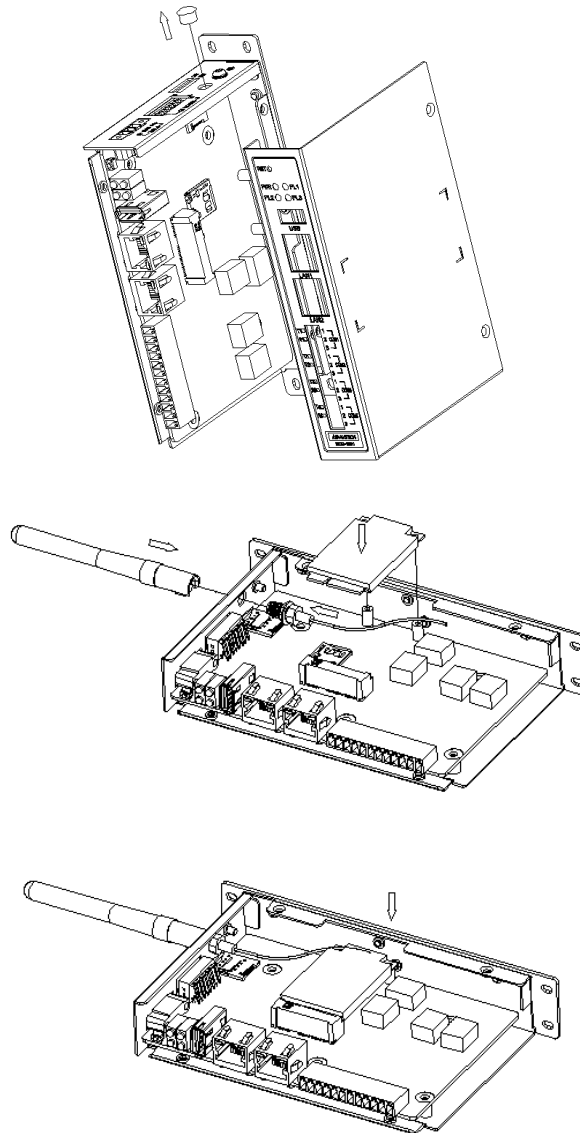

**Figure 3.14 SD & SIM Card Installation**

### 3.3.3 Installing a Wireless Module Card and Antenna (Optional)

For optional wireless module card and antenna, please contact Advantech for wireless solution kit.

- Top panel with pre-cut antenna holes.



- Wireless module card (mPCIe), internal coaxial cable with standard SMA connector and antenna.  
For more information about internal coaxial cable, please refer to the datasheet or contact Advantech.

## Chapter 3 Wiring and Installation

**ADVANTECH***Enabling an Intelligent Planet*

## [www.advantech.com](http://www.advantech.com)

Please verify specifications before quoting. This guide is intended for reference purposes only.

All product specifications are subject to change without notice.

No part of this publication may be reproduced in any form or by any means, such as electronically, by photocopying, recording, or otherwise, without prior written permission from the publisher.

All brand and product names are trademarks or registered trademarks of their respective companies.

© Advantech Co., Ltd. 2024